

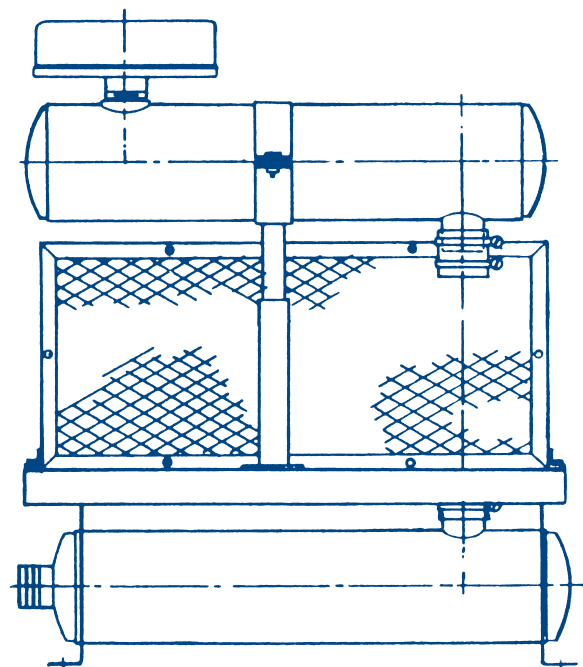

Specialists in Industrial Silencing

Stoddard Silencers, Inc.
1017 Progress Drive • Grayslake, Illinois 60030
Telephone (847) 223-8636 • FAX (847) 223-8638
E-Mail - info @ stoddardsilencersinc.com
Web page - www.stoddardsilencersinc.com

PACKAGED DISCHARGE SILENCERS



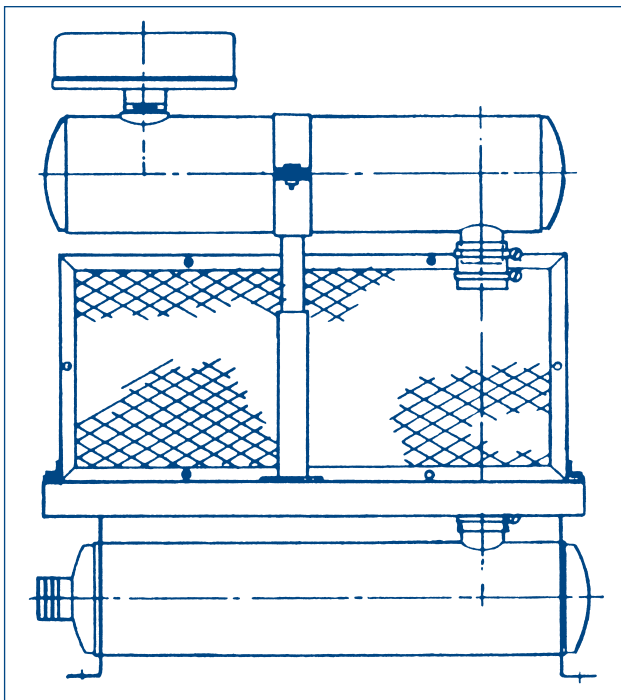

The PD is a discharge silencer for blowers on which the blower, motor and belt guard are mounted as an integral part of the silencer. The PD is designed to facilitate package assembly thereby reducing labor and the overall cost of assembling smaller blower packages. The design also enables the package to be pretested and shipped to the jobsite without any disassembly.

The PD incorporates all the benefits of the D33H and D13H series silencers seen in Bulletin "D". The inlet is designed to accept a slip-on type flex connector. Intake filter silencers, intake silencers, flex connectors (with clamps), belt guards and intake silencer supports are also available from STODDARD SILENCERS, making the purchase of accessories for the PD easier. Blowers, motors and slide rails are not included; however, special flanges, pressure relief valve connections, special finishes and special materials of construction are available at an additional cost.

Intake Silencers Size Selection Chart

Silencer Size	2	2½	3	4	5	6
Inlet CFM	79-128	129-183	184-378	379-551	552-860	861-1235

Discharge Silencers Size Selection Chart

Discharge Silencer Size	ICFM Range at Blower Inlet					
	4 PSIG 112°F	6 PSIG 134°F	8 PSIG 156°F	10 PSIG 178°F	12 PSIG 200°F	15 PSIG 233°F
2	90-148	96-158	102-167	107-175	111-183	118-194
2½	149-210	159-224	168-237	176-249	184-260	195-275
3	211-325	225-347	238-367	250-385	261-402	276-426
4	326-564	348-601	368-636	386-667	403-697	427-738
5	565-881	602-939	637-994	668-1042	698-1090	739-1153
6	882-1265	940-1348	995-1427	1043-1497	1091-1565	1154-1656

Silencer Model Selection Chart

If Blower RPM Is	Blower Gear Size								
	2	2½	3	4	4½	5	6	7	8
AT OR ABOVE	6297	5038	4198	3148	2798	2519	2099	1799	1574
	Use D33R Intake Silencer & PD33 Discharge Silencer (PD33 Package)								
BETWEEN (MAX)	6298	5039	4199	3149	2799	2520	2100	1800	1575
(Min)	5151	4124	3434	2944	2579	2059	1719	1469	1284
	Use D13R Intake Silencer & PD33 Discharge Silencer (PD46 Package)								
AT OR BELOW	5152	4125	3435	2945	2580	2060	1720	1470	1285
	Use D13R Intake Silencer & PD13 Discharge Silencer (PD13 Package)								

Silencer Pressure Drop Calculations

Intake Silencer Pressure Drop Calculations

1. Determine inlet velocity based on size from selection chart.

$$\text{Inlet Velocity FPM} = \frac{\text{Inlet CFM} \times 186.4}{(\text{Silencer Size})^2} = \text{(Feet Per Minute)}$$

Note: Inlet CFM refers to inlet capacity of blower

$$\text{Inlet Velocity} = \left(\frac{\text{Inlet CFM} \times 186.4}{(\text{Silencer Size})^2} \right) \times 186.4 = \text{_____ Feet Per Minute}$$

2. Convert inlet velocity to velocity pressure

$$\text{Velocity Pressure} = \left(\frac{\text{Inlet Velocity}}{4000} \right)^2 = \text{(Inches of Water)}$$

Note: Inlet velocity was determined in step one above.

$$\text{Velocity Pressure} = \left(\frac{\text{Inlet Velocity}}{4000} \right)^2 = \text{_____ inches of water}$$

3. Calculate pressure drop across silencer size selected.

$$\text{Pressure Drop} = \text{Velocity Pressure} \times \text{Friction Factor} = \text{(Inches of Water)}$$

Note: Velocity pressure determined in step two above.

$$\text{Pressure Drop} = \text{_____} \times 4.2 = \text{_____ inches of water.}$$

Discharge Silencer Pressure Drop Calculations

(Data Required - Blower ICFM, Discharge Pressure & Temperature)

1. Determine Discharge velocity in feet per minute for silencer size selected from sizing chart.

$$\text{Discharge Velocity} = \frac{5.17 \times \text{ICFM} \times (460 + \text{Discharge Temp. } ^\circ\text{F})}{(\text{Silencer Size})^2 \times (14.7 + \text{Discharge Press. PSIG})}$$

$$\text{Discharge Velocity} = \frac{5.17 \times \text{_____} \times (460 + \text{_____ } ^\circ\text{F})}{(\text{_____})^2 \times (14.7 + \text{_____ PSIG})}$$

$$\text{Discharge Velocity} = \text{_____ FPM}$$

2. Convert Discharge Velocity (FPM) to Velocity Pressure. (inches of water)

$$\text{Velocity Pressure} = \left(\frac{\text{Discharge Velocity}}{4000} \right)^2$$

$$\text{Velocity Pressure} = \left(\frac{\text{_____}}{4000} \right)^2$$

$$\text{Velocity Pressure} = \text{_____ inches of water}$$

3. Determine Discharge Silencer Pressure Drop - (inches of water)

$$\text{Pressure Drop} = \text{Velocity Pressure} \times 151 \times \frac{(14.7 + \text{Disch. Press. PSIG})}{(460 + \text{Disch. Temp. } ^\circ\text{F})}$$

$$\text{Pressure Drop} = \text{_____} \times 151 \times \frac{(14.7 + \text{_____})}{(460 + \text{_____})}$$

$$\text{Pressure Drop} = \text{_____ inches of water}$$