

INLINE AIR FILTERS

F65V

INLINE AIR FILTERS - VACUUM SERVICE ONLY

The Series F65V Inline Air Filter is designed to mount directly in the air piping system for engines, blowers or compressors. The filter element, which is fabricated from pleated paper media, has an efficiency of 99% on 1 micron particles and larger. The housing is designed to withstand a full vacuum. Pressure taps are provided on the intake and discharge nozzles for installation of a pressure drop indicator or switch by the customer. The F65V Inline Air Filter surfaces are prime coated with a red oxide primer.

ALTERNATE FILTRATION MEDIA AVAILABLE FOR F65V

- Cleanable Polyurethane Foam - 98% on 10 micron particles
- Cleanable Polyester Felt - 98% on 3 micron particles
- Epoxy Coated Wire Mesh - 90% on 10 micron particles (When Oil Wetted)

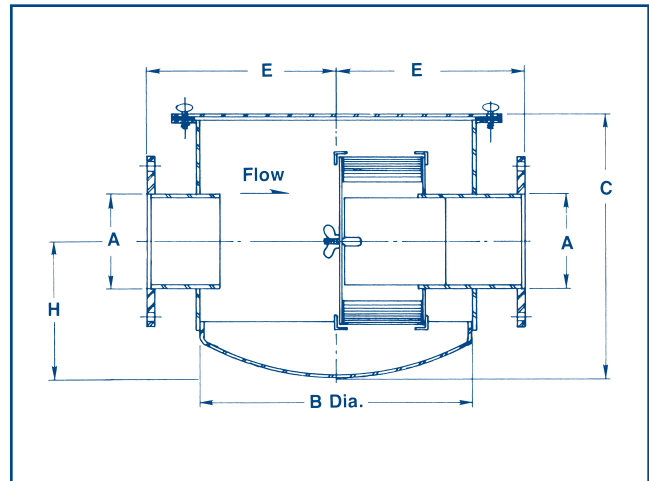

FOR PRESSURE SERVICE USE F65 (See Page 2)

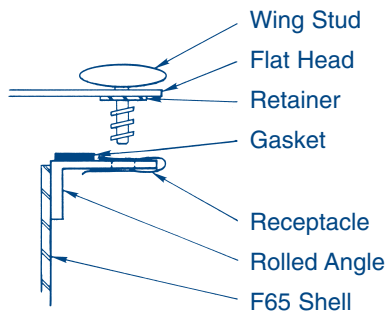

F65V up to and including 8" size:

Coarse threaded wing studs allow for easy access to the F65V for servicing the filter elements. See diagram at left.

F65V SERIES

MODEL	A	B	C	E	H	RATED CFM ⁽¹⁾	WEIGHT	REPLACEMENT ELEMENT NUMBER
F65V-2	2 NPT	12	10 ³ / ₄	9	5	135	38	F8-108
F65V-2 ¹ / ₂	2 ¹ / ₂ NPT	12	10 ³ / ₄	9	5	180	40	F8-108
F65V-3	3 NPT	16	15 ¹ / ₄	11	7	285	70	F8-109
F65V-4	*4 FLG	16	15 ¹ / ₄	11	7	520	77	F8-109
F65V-5	*5 FLG	16	15 ¹ / ₄	11	7	750	80	F8-109
F65V-6	*6 FLG	18	18 ⁵ / ₈	12	10	1075	100	F8-110
F65V-8	*8 FLG	24	19 ¹ / ₂	15	10	1800	180	F8-111

*Flanges match 125# ASA. Diameter and Drilling.

(1) Rated capacity is based upon a maximum exit velocity of 5500 fpm.